

Berry Metal Awarded Contract for Vertical Tundish Preheater by Major Mid-Western EAF Mill.

Berry Metal Company (BMC) is pleased to announced that the company was contracted to design and install a new Vertical Tundish Heater for a major mid-western EAF mill. The equipment is in process and will be installed in August/September of 2021.

The Tundish Preheater, using natural gas and air burners, is a Berry Metal proprietary design. The Preheater features independent Air and Natural Gas flow control, and dual burners that each produce up to 5.5 million BTUs for rapid and even heating.

The Berry Preheater replaces an aging and inefficient unit that became unreliable. The Berry Preheater consumes less energy and operates at lower costs.

"Our goal is to help supercharge our customers overall EAF performance by improving efficiency, lowering operating costs and increasing throughput," said David Werner President and Chief Operating Officer. "Increasing the effectiveness of Tundish Preheating is one piece of puzzle and we're excited to have been selected to produce this equipment."

About Berry Metal Company: BMC is more than a technology supplier... Since 1951, BMC has provided proven dependable manufacturing with continuous product innovation and improvement. We are an engineering company with unparalleled manufacturing capabilities. We provide dependable and ground-breaking furnace solutions for steelmakers. And we create long-term relationships by supporting those solutions through a "boots on-the-ground" approach because we are invested in our clients and their continued success. The Berry EAF portfolio includes chemical energy, lime injection, carbon injection, ladle and tundish preheaters, cooling panels, leak detection systems, repairs, and engineering in and around the furnace and caster areas of the EAF.

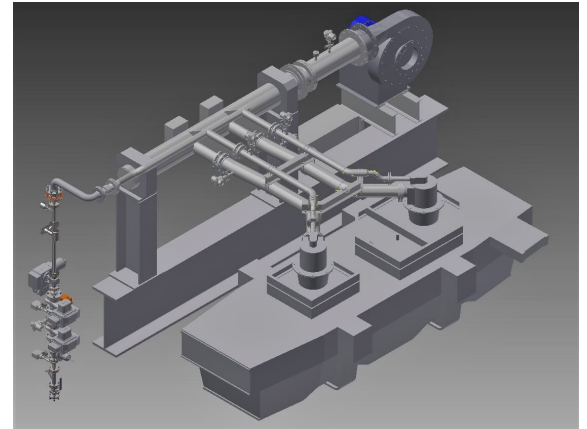

Berry Metal Vertical Tundish Preheater